

Reading the Ozone Test Strip

Field Guide

Task

Complete the measurement of surface ozone concentration after the ozone test strip has been exposed for one hour.

Record cloud conditions, current air temperature, wind direction, and relative humidity.

Record cloud conditions, current air temperature, wind direction, and relative humidity.

What You Need

- Ozone Test Strip Scanner
- Clipboard
- [Ozone Data Sheet](#)
- Pen or pencil
- GLOBE Cloud Chart
- Sling Psychrometer OR Digital Hygrometer
- [Cloud Cover Field Guide](#)
- [Cloud Type Field Guide](#)
- [Measuring Wind Direction Field Guide](#)
- [Sling Psychrometer Field Guide](#) OR [Digital Hygrometer Field Guide](#)
- Wind Direction Instrument
- Key to your instrument shelter
- A clock or watch accurate to the nearest minute

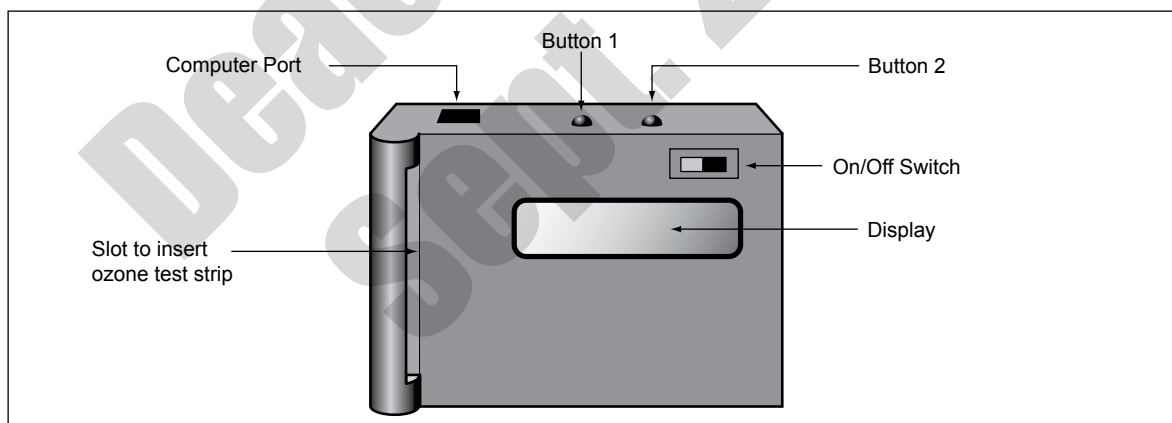

In the Field

1. Place the scanner in the instrument shelter and turn it on. Let it run 30 seconds to adjust to climate. (Do not touch any other buttons except the on/off switch if scanner turns off) You should see something like the following display:



```
MODE    AUTO    SAVE
01      1HR PPB  133
```

2. Remove the test strip from the clip; be careful not to touch the chemical part of the strip.

In the Field or Classroom

3. Slide the strip into the slot on top of the scanner until the bottom of the strip touches the base of the scanner and won't slide in any further. The chemical part of the strip should face the display
4. The reading should stop fluctuating after 5-10 seconds. If it fluctuates between two numbers, choose the lower of the two readings after the test paper has been in the scanner for 10-15 seconds.
5. Record the ppb reading on your [Data Sheet](#) and turn scanner off. If the reading fluctuates between two numbers, choose the lower of the two readings after the test paper has been in the scanner for 5-10 seconds. Place the strip into a sealed plastic bag.
6. Record the time you read the ozone strip.
7. Determine cloud cover and cloud type following the [Cloud Cover](#) and [Cloud Type Field Guides](#).
8. Read and record the current air temperature.
9. Determine and record the wind direction.
10. Measure and record the relative humidity using either a sling psychrometer or digital hygrometer.

Note: The new scanner model automatically turns itself off after a minute. If this happens, turn it back on to complete your task. It is not uncommon for the scanner to display more than one value, because of the nature of the electronics in the scanner and the color on the exposed strip is rarely completely uniform (although it may appear that way to the naked eye). It is common that the concentration shown in the display fluctuates among several values and eventually starts to increase the longer the strip remains in the unit. Because the measurement accuracy is 10 ppb, fluctuating numbers within a range of 1-5 ppb are acceptable. The goal of the [Ozone Protocol](#) is to be able to distinguish between values that are regarded as low (0-20 ppb), normal (30-50ppb) and high (>60 ppb).